

frost-trol
SOLID LINES



PLUG-IN

ONTARIO

Island



ONTARIO 2E

PIOP|12|41|12|CO|ND|17



PLUG-IN

Highlights

Cabinet designed to operate with natural refrigerant R290 in compliance with F-Gas regulations.

Possibility to include sliding doors in the structure of the cabinet to improve its energy efficiency.

Possibility to include wheels that allow the quick transfer of the cabinet in the supermarket, easily changing the layout.

Plug-in perimeter island specially designed for the sale of products in promotion or take away.

Panoramic gable ends.

Standard equipment

Available with 1 or 2 evaporators

R290 Refrigerant

Ventilated cooling system

Electronic control

Condensate evaporation tray

Electric defrost

Stainless steel bumpers (front and rear)

Mechanical fans

Inner painted in epoxy

Plastic packaging

Protective grill on fans



ONTARIO 1E SD

PIOP|12|91|12|C0|SD|17



PLUG-IN

Highlights

Cabinet designed to operate with natural refrigerant R290 in compliance with F-Gas regulations.

Possibility to include sliding doors in the structure of the cabinet to improve its energy efficiency.

Possibility to include wheels that allow the quick transfer of the cabinet in the supermarket, easily changing the layout.

Plug-in perimeter island specially designed for the sale of products in promotion or take away.

Panoramic gable ends.

Standard equipment

vailable with 1 or 2 evaporators

R290 Refrigerant

Ventilated cooling system

Electronic control

Condensate evaporation tray

Electric defrost

tainless steel bumpers (front and rear)

Mechanical fans

Inner painted in epoxy

Plastic packaging

Protective grill on fans

PIOP129112C0SD17



ONTARIO

PIOP|12|91|12|CO|ND|17



PLUG-IN

Highlights

Cabinet designed to operate with natural refrigerant R290 in compliance with F-Gas regulations.

Possibility to include sliding doors in the structure of the cabinet to improve its energy efficiency.

Possibility to include wheels that allow the quick transfer of the cabinet in the supermarket, easily changing the layout.

Plug-in perimeter island specially designed for the sale of products in promotion or take away.

Panoramic gable ends.

Standard equipment

vailable with 1 or 2 evaporators

R290 Refrigerant

Ventilated cooling system

Electronic control

Condensate evaporation tray

Electric defrost

tainless steel bumpers (front and rear)

Mechanical fans

Inner painted in epoxy

Plastic packaging

Protective grill on fans

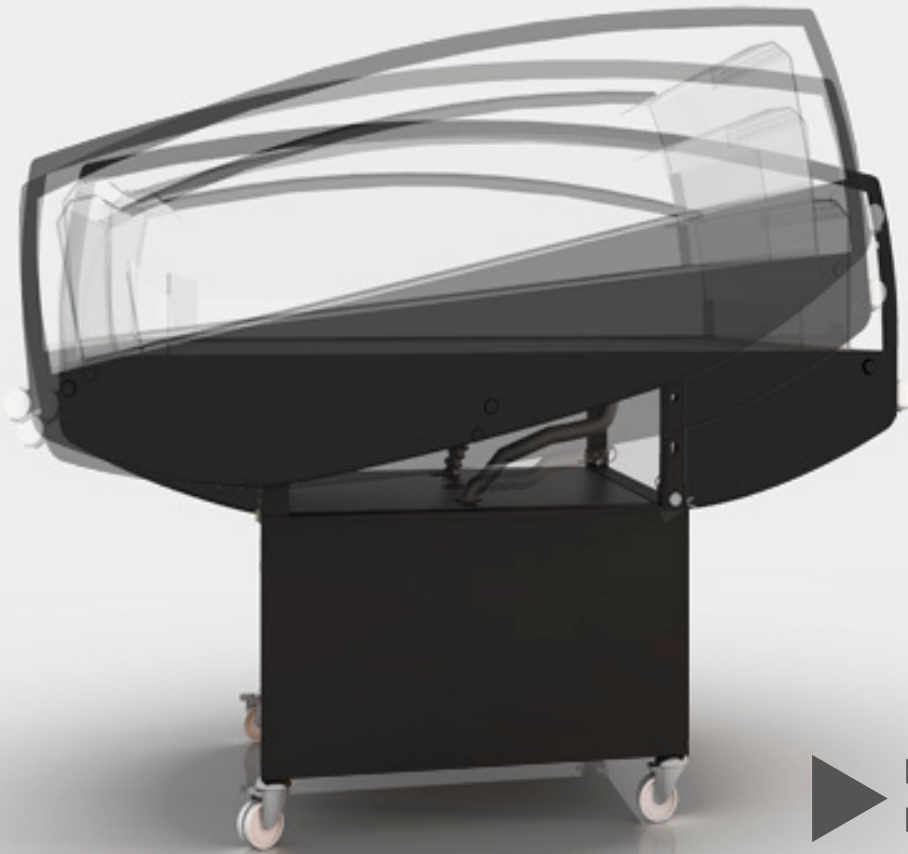

▶ IN THE ONTARIO 1E VERSION THE EXPOSURE CAN BE TILTED

Options and Accessories

- Sliding doors (SD version)
- Interior in stainless steel Aisi-304 o Aisi-316
- Superstructure with glass shelf
- EC fans
- Night covers
- Wheels kit
- Carton packaging
- Treated wood packaging
- Treated wood packaging Plus



▶ STAINLESS STEEL BUMPERS



▶ OPTIONAL WHEEL KIT

ONTARIO 1E
PIOP129112COND17
 Available modulations
 1250

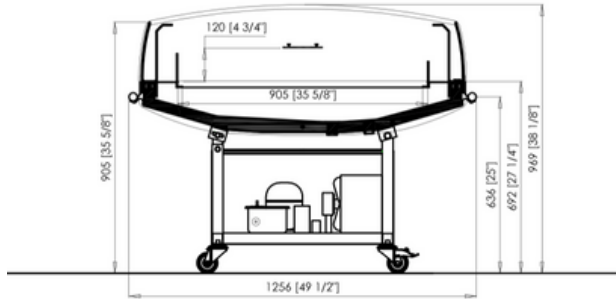

ONTARIO 2E
PIOP124112COND17
 Available modulations
 1250

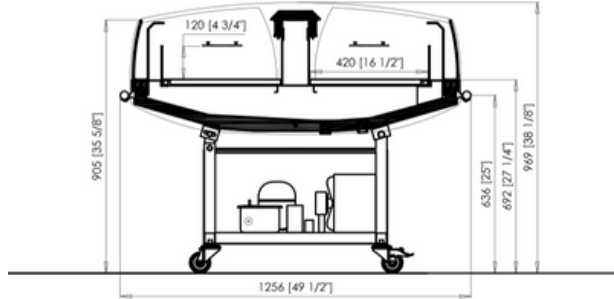

ONTARIO 1E
PIOP129112COSD17
 Available modulations
 1250

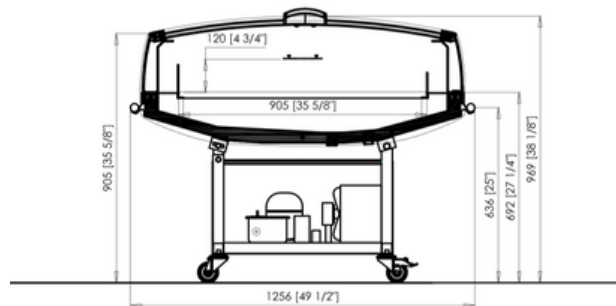

frost-trol



www.frost-trol.com



FROST-TROL, S.A
PLANTA 1
CV 159 KM 2 CP. 12180
Cabanes (Castellón) España
+34 964 34 27 40

FROST-TROL, S.A
PLANTA 2
AVDA. DEL CASTELL VELL, 188
12180
Castellón - España
+34 964 34 27 40

FROST-TROL, S.A
MÉXICO
AV. PIRULES, 134 B ESQUINA CON AV.
TEJOCOTES - 54769
Cuautitlán Izcalli - Estado de México
+34 964 34 27 40

FROST-TROL, S.A
FRANCIA
BUREAU B09 RUE LE BOUVIER
92340 - BOURG LA REINE
(PARIS) FRANCE

FROST-TROL, S.A
DUBAI
GOLDCREST EXECUTIVE
JUMERIAH LAKES TOWERS
(DUBAI) EMIRATOS ÁRABES
UNIDOS

